

GENERAL RULES	39
Warnings	39
Symbols used in the manual.....	39
Transport and handling	39
Intended use of the device	39
Risks	39
Dispensing harmful and/or toxic liquids.....	40
Assembling the pump	40
Disassembling the pump.....	40
ETWIN SERIES METERING PUMP	40
General features of ETwin pumps	40
Operating principle of peristaltic pumps	41
Operating principle of electromagnetic pumps	41
Main features	41
Technical features of peristaltic version.....	42
Technical features of electromagnetic version	42
Materials in contact with additive in peristaltic version	42
Materials in contact with additive in electromagnetic version	42
Main additional functions	43
INSTALLATION	44
ETWIN	45
Control Panel	45
DIAGRAM OF THE ELECTRICAL CONNECTIONS	45
PRIMING FUNCTIONS: SCREEN	48
SET-POINT CONFIGURATION MENU	48
Access to probe setting, configuration and calibration menus	47
Setting pH, Rx Chlorine parameters	48
PROBES CONNECTION	50
pH probe connection	50
Rx probe connection	51

Cl probe connection.....	51
PROBES CALIBRATION MENU	51
pH probe calibration	52
Rx probe calibration.....	52
Cl probe calibration.....	53
MANUAL MODE SETTING MENU.....	53
SETTINGS MENU	54
Relay outputs.....	55
Inputs	57
Timer	57
Alarms	59
mA output	61
Visualization of the probe mVs	61
Activation delay	62
pH priority	62
Temperature.....	62
PPM scale values	63
Clock.....	63
Password.....	64
Setting the language.....	65
Reset.....	65
MAINTENANCE	65
INTERVENTION ON ETWIN PUMPS IN CASE OF FAILURE	66
Mechanical failures	66
Electrical faults	66
DRAWINGS.....	67
<u>Peristaltic and Electromagnetic Pump Exploded Drawings</u>	<u>67</u>

Warnings

Read the warnings below carefully. They provide important information regarding safe installation, use and maintenance. Store this manual with the utmost care for future reference.

The device complies with directive no. 2014/30/EU “electromagnetic compatibility” and no. 2014/35/EU “low voltage directive”.

The device is built in a professional manner. Its endurance and electrical and mechanical reliability will be more efficient if it is used properly and maintenance is carried out on a regular basis.

ATTENTION: Any work or repairs inside the device must be carried out by qualified and authorised personnel. We assume no liability due to failure to comply with this rule.

WARRANTY: 2 years (excluding parts subject to normal wear, namely: valves, fittings, pipe collars, tubes, filter and injection valve). Improper use of the device will void this warranty. The warranty is understood as ex-works or authorised distributors.

Symbols used in the manual

		
FORBIDDEN Precedes information regarding safety. Indicates a forbidden operation.	ATTENTION Precedes very important text to protect the health of persons exposed or the machine itself.	INFORMATION NOTE Precedes information concerning use of the device.

Transport and handling

The device must be transported as indicated on the box. Shipping by any means, even if free of carriage of the purchaser or recipient, is carried out at the purchaser's risk. Claim for missing materials must be made within 10 days of arrival of the goods. Whereas defective material within 30 days of receipt. If the device is to be replaced, it must be agreed upon with authorised personnel or the authorised distributor.

Intended use of the device



The device must only be used as expressly intended and namely for dosing liquids. Any other use is considered improper and therefore dangerous. The device is not intended to be used for any applications not foreseen during the design stage. For further explanations, the customer must contact our offices for information as to the type of pump in their possession and its correct use. The manufacturer shall not be held liable for any damage resulting from improper, erroneous or unreasonable use.

Risks

After removing the packaging, check the integrity of the device. If in doubt, do not use it and contact a qualified technician. The packing materials (such as plastic bags, polystyrene, etc.) must not be left within reach of children since they are potentially dangerous.

Before connecting the device, make sure that the rating corresponds to that of the mains. The rating is displayed on the adhesive label on the device itself

Execution of the electrical system must comply with the standards that define professional workmanship in the country where the system is made.

Use of any electrical device implies observance of some fundamental rules. In particular:

- do not touch the device with wet or damp hands or feet (e.g. swimming pools);
- do not leave the device exposed to atmospheric agents (rain, sun, etc.)
- do not allow the device to be used by children or persons incapable of using it without surveillance.

In case of failure and/or malfunctioning of the device, switch it off and do not tamper with it. For any repairs, please contact our service centres and request use of original spare parts. Failure to comply with the above can jeopardise the safety of the pump.

If you decide to no longer to use a device, it is recommended to make it inoperable by unplugging it from the mains.

- Make sure it is switched off electrically (both polarities), disconnecting the conductors from the contact points of the mains by opening the omnipolar switch with at least 3 mm between the contacts.
- Appropriately eliminate any pressure in the peristaltic pumps and supply pipes, paying the utmost attention.
- Eliminate all the liquid in the pinch tubes.

In case of any leaks in the hydraulic system of the pump (breakage of injection valve, filter, pipes), you must stop the pump, depressurise the supply pipe and then proceed with maintenance operations using appropriate safety measures (gloves, goggles, overalls, etc.).

Dispensing harmful and/or toxic liquids



The following rules, along with the instructions in this booklet, must be kept in mind to avoid personal harm or property damage due to contact with harmful liquids or the intake of toxic fumes:

- Always work as recommended by the manufacturer of the liquid being used.
- Use appropriate personal protective equipment
- Check that the hydraulic part of the pumps has no damage or breakage. Only use the device if in perfect working order.
- Use tubes suited to the liquid and the operating conditions of the plant, inserting them, if necessary, into protective PVC pipes
- Before deactivating the device, you must neutralise the hydraulic part with an appropriate reagent.

Assembling the pump

All metering pumps manufactured by us are usually supplied fully assembled. For further explanations, please consult the attachment at the end of this manual where exploded drawings of the pumps and all parts with relative nomenclature are displayed in order to have a complete picture of the equipment. These drawings are anyhow required to recognise the malfunctioning or defective parts.

Disassembling the pump

You must always pay the utmost attention when disassembling the pump or anyhow before performing maintenance on it. We recommend consulting the attached drawings and referring to the previous chapter “**RISKS**” before beginning any operation.

ETWIN SERIES METERING PUMP



General features of ETwin pumps

ETwin is an easy to use device, consisting of a pair of metering pumps (electromagnetic or peristaltic) and electronics capable of measuring the chemical values of water in a swimming pool, such as pH, redox potential (mV) and chlorine concentration (in ppm). These parameters can be controlled by dosing appropriate additives with the pumps supplied with eTwin. The materials eTwin is made of are suited for dosing the most common products used in the swimming pool industry.

See the instructions for use supplied by the manufacturer of the chemicals for the selection and correct use of the additives used in swimming pools.

- **Default settings**
- **eTwin pH – RX** Set-point = 7.2pH; intervention: ACID, Set-point= 700mV; intervention: OXIDANT
- **eTwin Cl – pH** Set-point = 7.2pH; intervention: ACID, 1 ppm (scale 0 - 2 ppm); DIRECT intervention
- **eTwin 2 pH** Set-point = 7.2pH; intervention: ACID on both measurements

- **Range of values:**
- pH: **0÷14**
- Redox: **-1000 ÷ +1400 mV**
- PPM: **0÷2, 0÷10, 0÷20, 0÷200 ppm**
- Temperature **0÷100 °C (PT100)**

Operating principle of peristaltic pumps

By peristalsis we mean the propulsive motion of automatic contractions inside a channel or pipe, from whence the term peristaltic action. Through the mechanical simulation of biological peristalsis, rollers compress the walls of a pipe forming a seal during their movement, then the compressed part of the pipe goes back to its original shape thus suctioning fluid by means of the negative pressure created. The fluid follows the roller until the pipe is no longer compressed. At this point, a second roller is already compressing the pipe to avoid a backflow, pushing the initial dosage of fluid out of the pump and repeating the suction action. Rollers mounted on special rotors allow the pump to run continuously thanks to their inlet/outlet action.

Operating principle of electromagnetic pumps

The metering pump operates by means of a PTFE (Teflon®) diaphragm mounted on the piston of an electromagnet. When the piston of the electromagnet is attracted, it creates pressure on the pump body thus ejecting liquid from the supply valve. When the electric pulse is finished, a spring brings the piston back to its initial position flowing liquid through the suction valve. The pump needs no lubrication and practically no maintenance thanks to its easy use. The materials used to build the pump make it fit for dispensing chemically aggressive liquids. The metering pump was designed for flow rates from 2 to 5 l/h and pressures from 5 to 6 bar according to the model.

Main features

- Device manufactured according to **CE** standards
- Chassis made of: Polypropylene
- Designed for fitting level probe
- Standard electric power supply (fluctuations of a maximum $\pm 10\%$ are allowed): 230 V a.c. 50/60 Hz single phase.

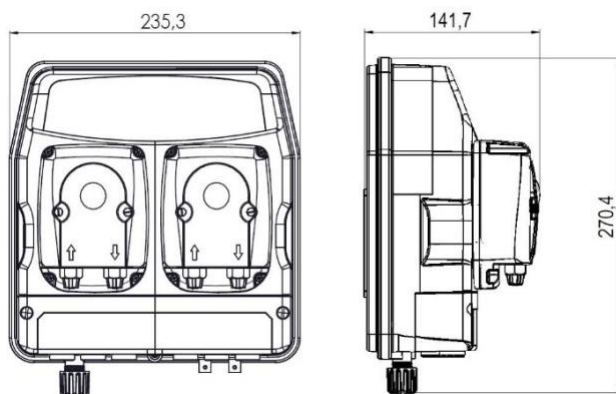

Fig. 1 – Views and dimensions – peristaltic version

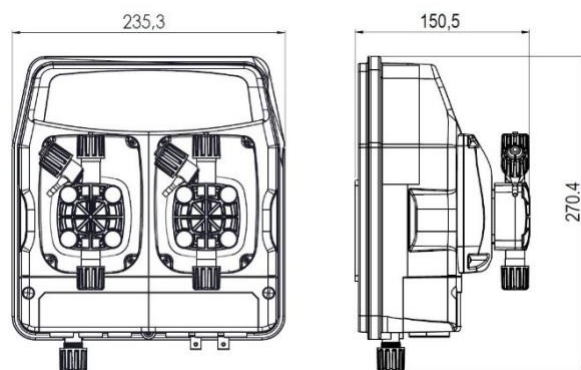

Fig. 2 – Views and dimensions – electromagnetic version

Technical features of peristaltic version

Type	MAX Flow rate [l/h]	MAX Pressure [bar]	Weight [Kg]	Dimensions [mm]			Absorbed Power [W]	Rotation Speed [RPM]	Pipe [ODxID] [mm]
				Height	Width	Depth			
eTwin	1.5	1.5	1.5	270	235	140	15	20	4 x 6
	3	1.5	1.5	270	235	140	15	40	4 x 6

Technical features of electromagnetic version

Type	MAX Flow rate [l/h]	MAX Pressure [bar]	Weight [Kg]	Dimensions [mm]			Absorbed Power [W]	Injections [pul/1']	Pipe [ODxID] [mm]
				Height	Width	Depth			
eTwin	2.0	6.0	3.5	270	235	148	65	120	4 x 6
	5.0	5.0	3.5	270	235	148	65	120	4 x 6

Materials in contact with additive in peristaltic version

- Pinch tube: Santoprene®
- Bottom filter: Standard – Polypropylene®
- Injection valve: Standard – Polypropylene®
- Suction pipe: PVC Cristal®
- Supply pipe: Polyethylene®

Materials in contact with additive in electromagnetic version

- Pump body: PVDF (polyvinyl chloride)
- O-Ring: Viton®
- Valves: Ceramic
- Bottom filter: Standard – Polypropylene®
- Injection valve: Standard – Polypropylene®
- Suction pipe: PVC Cristal®
- Supply pipe: Polyethylene®

Main additional functions

Function	Description
LEVEL ALARM	Operating if enabled, the opening or closing of the contact on the level probe indicates that the additive in the tank has finished; the instrument deactivates the relays of the set points and displays an alarm. Possibility of choosing between normally open contact (default setting) or normally closed. Possibility of choosing triggering of the level alarm for each measuring channel.
PROXIMITY SENSOR	The input can be activated to connect the proximity sensor which detects the flow in the probe holder and enables triggering of the instrument. Possibility of choosing between normally open contact (default setting) or normally closed. Possibility of choosing to associate it to one or both pumps (default).
MINIMUM AND MAXIMUM ALARM	You may set the minimum and maximum thresholds of the measured quantity, beyond which the instrument triggers an alarm. Possibility of choosing triggering of the minimum and maximum alarm for each measuring channel. You may also associate enabling of the alarm relay.
OVERDOSAGE ALARM	You may set an operating time limit for the pumps, beyond which, if the set-point values are not reached, an alarm triggers and the device shuts down. The count includes the service time, considering the actual operation of the pumps, therefore excluding pauses in proportional operation. The relay output is always enabled.
ACTIVATION DELAY	It defines a time, starting from switch on, during which the device does not dose or measure. When switched on, a countdown is displayed indicating the time remaining until the measuring channel is activated. One for each measuring channel. This function is useful when the sensors need a certain amount of time before detecting a reliable measurement. Different delay values can be chosen for each measuring channel.
CLOCK	To set the date and time. These parameters must be set if timer mode is activated.
TEMPERATURE PROBE	A two-wire PT100 probe may be connected to the instrument to compensate the measurement.
ALARM RELAY SERVICES OUTPUT	This can be enabled through the menus of all the alarms, remotely indicating any alarm situations. Features: 1 exchange – 250V a.c. 5A (resistive load) and 1A (inductive load).
OUTPUT CURRENT (mA)	The instrument has an output in current (4-20 mA), directly proportional to the reading of the measurement made by the instrument. By acting on the DOWN ARROW key while it is displayed, you may view the current value present on the output.
TIMER	Weekly and daily timer. 4 daily ON/OFF cycles. Set to the minute.
MULTI-LANGUAGE	Language of the menus: Italian/English/German/Spanish/Portuguese/French
PASSWORD	A password can be set to separately protect CALIBRATION, SET-POINT, SETTINGS and STANDBY
RESET	Possibility of performing the reset to restore the default settings
PRIMING	It is possible to operate the pumps regardless of the measurement value detected by the probes, for example to prime them during the installation procedure

INSTALLATION



Install the pump in a dry area away from heat sources at a maximum ambient temperature of 40 °C, while the minimum operating temperature depends on the liquid to be dosed which must always remain in the fluid state.

Comply with standards in force in the different countries regarding the electrical installation (Fig. 2). **If the power cord does not have a plug, the device must be connected to the mains by means of an omnipolar disconnecting switch with at least 3 mm between the contacts. All the power circuits must be interrupted before accessing the connection devices.**

100 - 250 VAC 50/60 HZ

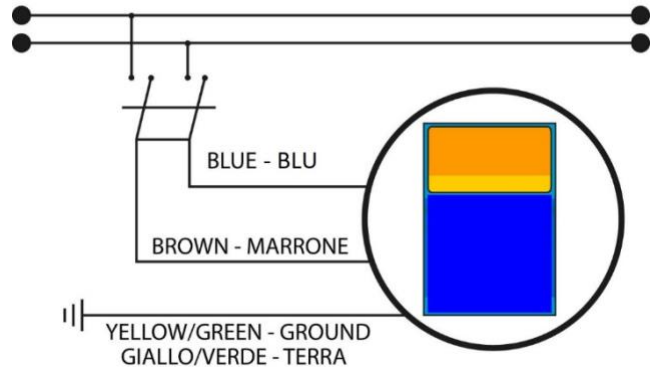

Fig. 3 – Electrical connection

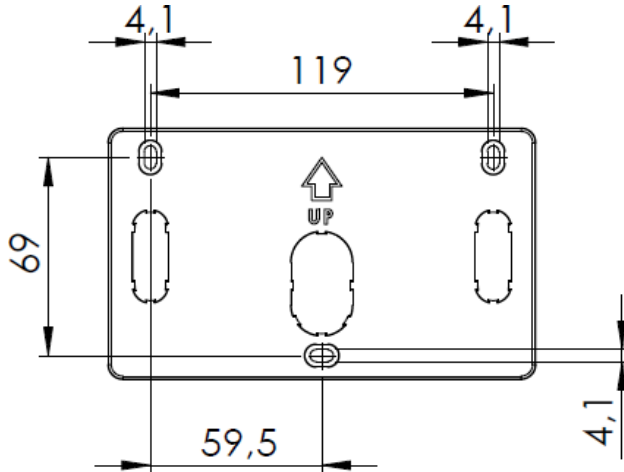

Fig. 4 – Drilling support bracket

The device is supplied with a bracket to fix it to the wall and relative plugs for masonry walls. **Always use a plug appropriate to the available support.** The layout of the holes to be drilled on the support is displayed in

Fig. 1 – Views and dimensions – peristaltic version

Fig. 2 – Views and dimensions –

electromagnetic version

Position the pump as in the figure, considering that it must be secured both below and above the level of the liquid to be dosed within a maximum limit of 2 m. The injection points must always be higher than the liquid to be injected. For liquids which let out aggressive fumes, do not install the pump above the tanks unless they are watertight.

Insert the tubes all the way on the relative tapered couplings and block them with the specific ring nuts. Do not make elbows on the supply and suction pipe. Apply a 3/8" gas female fitting on the piping of the plant to be treated, at the most suitable point to inject the product to be dosed. This fitting is not included in the supply. Screw the injection valve in the fitting using Teflon® as a gasket. Connect the tube to the tapered coupling of the injection valve and block it with the specific ring nut. The injection valve is also a check valve.

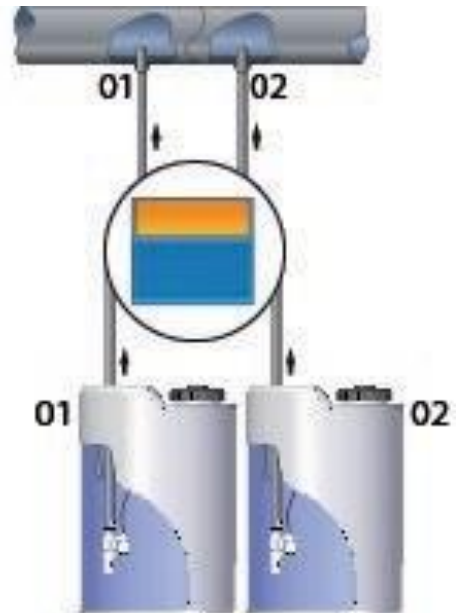
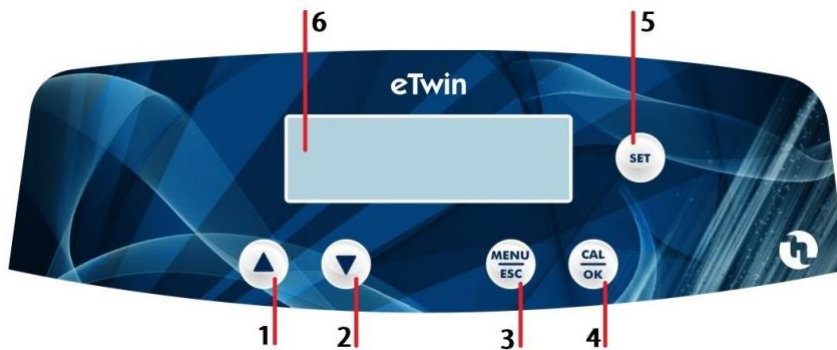

Fig. 5 – Standard installation

Control Panel

The following figure depicts the control panel with the description of the functions of the different keys.



1		Increase values button
2		Decrease values button
3		MENU - ESC button
4		Calibration (CAL) of instrument and OK confirmation button
5		Set-point display and setting button
6		Digital screen

Fig. 6 – Control Panel

DIAGRAM OF THE ELECTRICAL CONNECTIONS



To connect the accessories and peripheral devices to the pump, remove the front cover, acting on the two plastic screws on the sides of the cover with a flat headed 5mm (at least) screwdriver to reach the terminal board.

The terminal board consists of spring terminals for quick coupling of the wires. Press the square “slotted” pin with a small flat headed screwdriver and insert the stripped wire in the corresponding terminal. **ATTENTION: exert slight pressure on the spring pin to avoid irreparably damaging the terminal board.**

Pass the cables through the rubber cable glands on the wall of the cover, using a screwdriver to remove the thin internal closing septum. Pay attention to perforation of the cable gland and wear appropriate protective equipment (gloves).

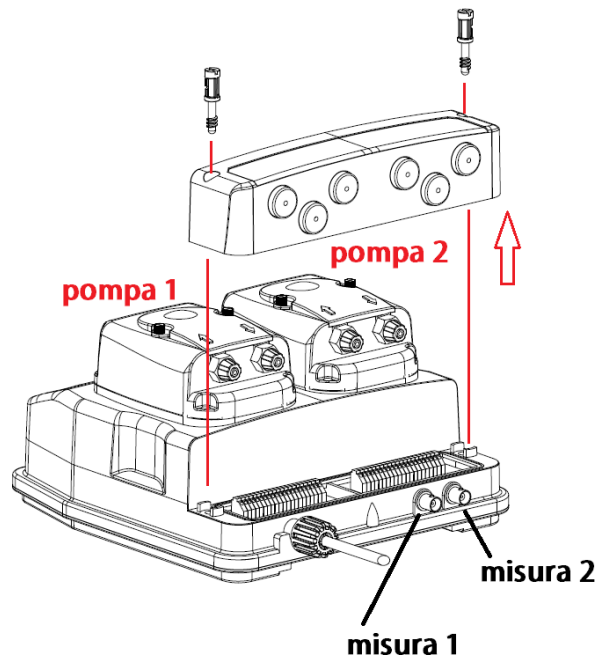

Fig. 7 – Opening terminal board cover and position of probe connectors



The probe connectors are located at the bottom of the device as shown in

Fig. 7 – Opening terminal board cover and position of probe connectors

. Set-points 1 and 2 are always matched respectively to measuring channels 1 and 2 on all eTwin pump models and versions.

Once the cables are connected, close the cover and delicately pull any extra cable out through the cable glands. ATTENTION: tighten the gasket as much as possible but not excessively so as not to damage the plastic screws.

The following table shows the allocations of measuring channels 1 and 2 according to your eTwin version.

Measurement - Version	pH - Rx	Chlorine - pH	pH - pH
Measurement 1	pH	Chlorine	pH
Measurement 2	Rx	pH	pH

Table 1 -Configuration of measurement channels of different eTwin versions

Right side terminal block J17	
No.	Description
1	RS485 (not enabled)
2	
3	
4	
5	Pump 1 Level Probe Input (-)
6	Pump 1 Level Probe Input (+)
7	Pump 2 Level Probe Input (-)
8	Pump 2 Level Probe Input (+)
9	Proximity Sensor Input (-)
10	Proximity Sensor Input (+)
11	External command (-)
12	External command (+)
13	mA output (-)
14	mA output (+)
15	PT100 input (-)
16	PT100 input (+)
17	+5V power supply. Chlorine pot. probe
18	+5V power supply. Chlorine pot. probe

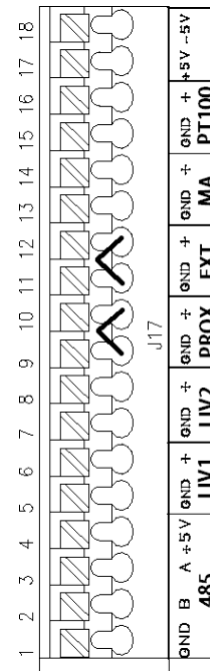

Fig. 8 – RIGHT terminal block J17

Left side terminal block J16		
No.	Description	
1	Relay L1 NO	
2	Relay L1 NC	
3	Relay L1 Common	
4	Relay L2 NO	
5	Relay L2 NC	
6	Relay L2 Common	
7	Relay L3 NO	
8	Relay L3 NC	
9	Relay L3 Common	
10	Not connected	
11		
12		
13	Relay L5 NO	Alarm
14	Relay L5 NC	
15	Relay L5 Common	

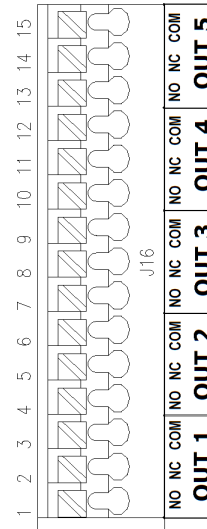

Fig. 9 – LEFT terminal block J16

Terminals 9-10 (proximity sensor) and 11-12 (external command) of the RIGHT terminal block called “J17” are short-circuited with removable jumpers. The default triggering mode for these input is set at NO (normally open). To leave the behaviour of the device unchanged, the jumpers can be removed and switched to NC (normally closed). For the operating modes, see the chapter on settings of the external inputs.

DESCRIPTION OF THE SCREEN

Access to probe setting, configuration and calibration menus

While browsing the different menu items on the right side of the screen, a series of icons are enabled indicating which keys can be pressed in that particular context.



you may press the **MENU/ESC** key



you may press the **CAL/OK** key



you may press the **ARROW** keys



In measuring mode, when icons 1, 2, 3 are lit it means that the relative relay is activated.

Instrument screen **MEASURING**



Instrument screen in **PAUSE**

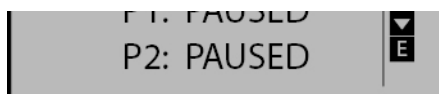

When the instrument is switched on, it stores the prior condition, PAUSE OR MEASURING.

PRIMING FUNCTIONS



To facilitate pump priming, it is equipped with the **PRIMING** function. It is recommended to open the purge bypass on the pump bodies (for eTwin with electromagnetic hydraulics) during the priming operations. The air purge fitting **must always be connected** to the relative tube with return to the suction tank.

This function can be activated in any operating mode (MEASURING or IN PAUSE) as follows:

- Press and hold the **UP ARROW** key for left hydraulics, or the **DOWN ARROW** key for right hydraulics.
- After about 5 seconds, the pump begins to dispense injections at the priming frequency (120 pul/min for electromagnetic pumps, at maximum speed for peristaltic pumps) until the operator releases the **UP/DOWN ARROW** key. The following screen appears on the display while pressing the key:

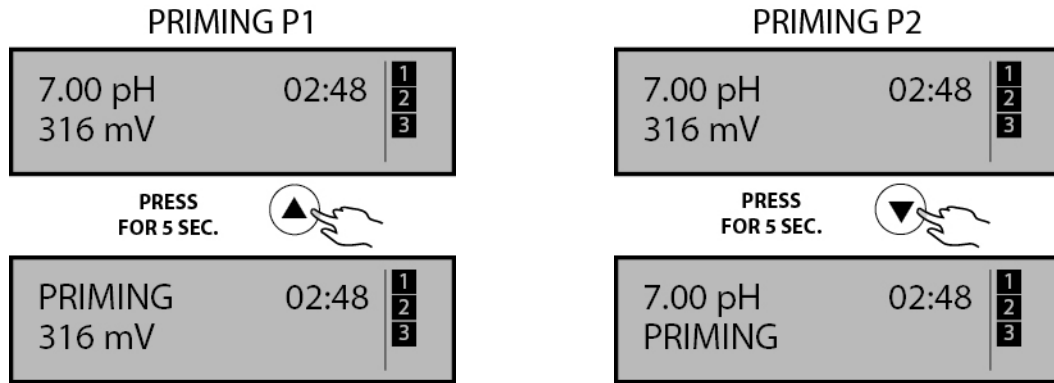

- The **PRIMING** function can be activated even if the pump is protected by **PASSWORD**.

SET-POINT CONFIGURATION MENU

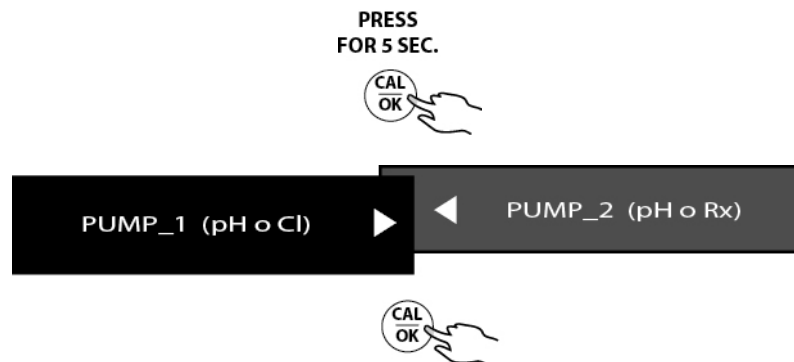

Setting pH, Rx Chlorine parameters

The following tables show the sequence of operations to set the operating parameters of the measurement on channel 1, Ph or Cl. The same process can be applied to channel 2 of the measurement (pH, Rx, Cl).

The current and stored values are highlighted with a dot to the right of the value.

Default set-point values 7.20 pH, 700mV, 1,50ppm.

In the set-point programming menu of the pH, Rx and Chlorine (PPM) modes, the following can be set:

- **SET-POINT:** intervention value and mode
- **INTERVENTION TYPE:** defines the field of application of the instrument
- **HYSTERESIS:** range around the set-point value within which the pumps are not activated. When the measurement leaves this interval, the pumps are activated
- **TEMPERATURE:** compensation of the measurement relating to the temperature (only for pH if enabled in **MANUAL** mode – see chapter *Temperature*)

- **CONSTANT:** the pumps operate at a fixed frequency or speed until they reach the set-point value.
- **PROPORTIONAL:** the time-pause intervals or the injection frequency decreases as the set point value approaches to limit oscillations of the measurement
- **INTERVAL:** intervention value for the maximum PROPORTIONAL dosage
- **MAXIMUM FLOW RATE:** full-scale value on which the proportionality of the dosage is regulated: 30÷300 sec. (peristaltic), 0÷100 % (electromagnetic)

The selection of the “**INTERVENTION TYPE**” parameter depends on the type of product dispensed.

- **pH:** If an acid product is used, the pump intervening with acid doses by pH values higher than the set-point to lower the value to the desired point. On the other hand for alkaline intervention, with dosing aimed at increasing the pH value, the pump doses with measures of pH lower than the set-point.
- **Rx:** If an oxidant product is used (e.g. sodium hypochlorite) the pump intervening with oxidant doses by mV values lower than the set-point to increase the value to the desired point. On the other hand for reducing agent intervention, with dosing aimed at decreasing the Rx value, the pump doses with measures of mV higher than the set-point.
- **Cl:** If an oxidant product is used (e.g. sodium hypochlorite) the direct intervention pump doses by ppm values lower than the set-point to increase the value to the desired point. On the other hand for inverse intervention, with dosing aimed at decreasing the CL value, the pump doses with measures of ppm higher than the set-point.



To confirm the changes, confirm all the parameters in the SETPOINT menu until you go back to the window “PUMP 1 or 2 SET-POINT”. You may exit the menu (from any parameter) without saving the changes by pressing the MENU/ESC button.

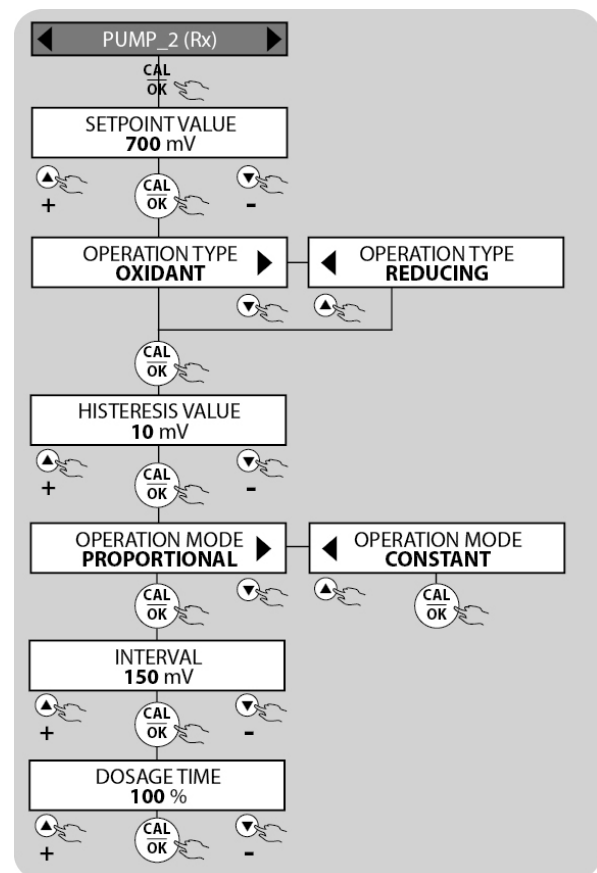
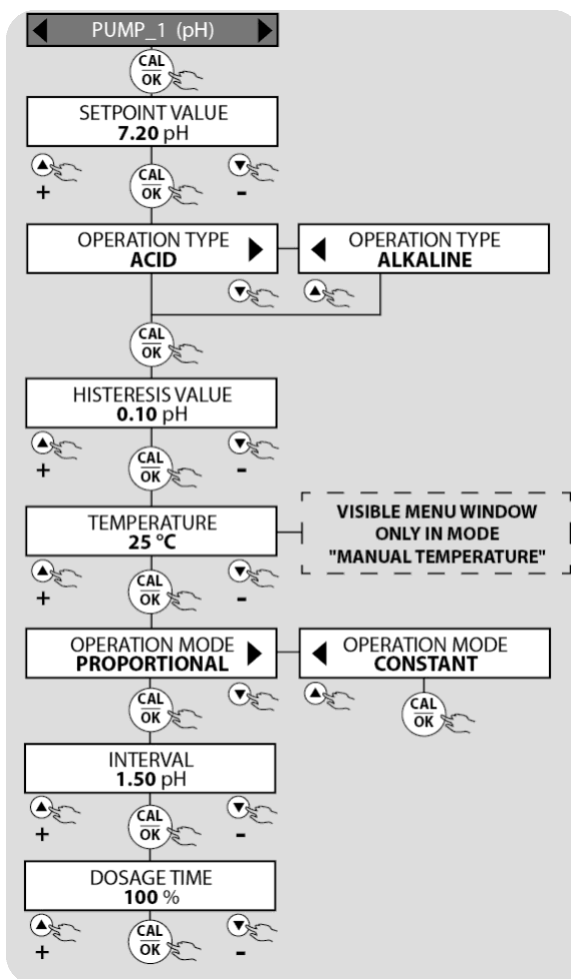

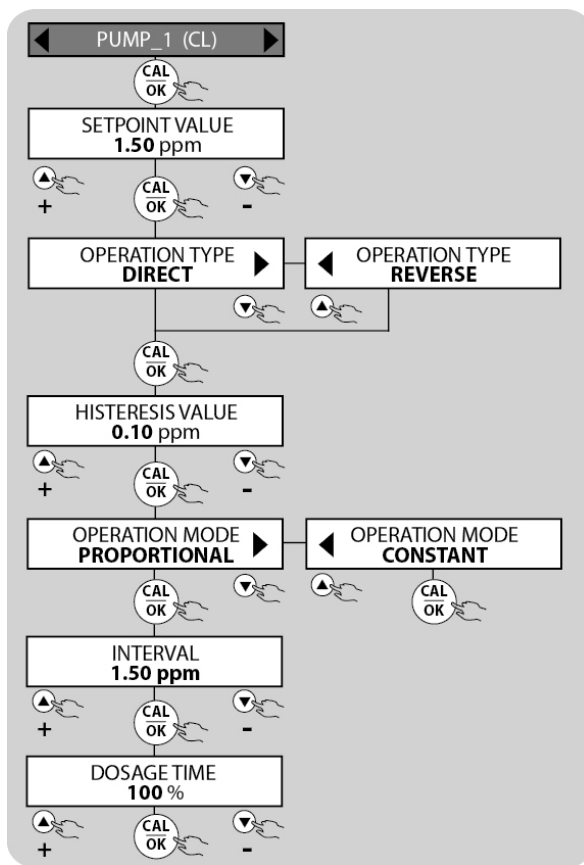

PROBES CONNECTION

pH probe connection

The following instructions apply to eTwin pH-Rx or pH-pH models where channel 1 is always allocated to the pH probe input. For CI-pH instruments, on the other hand, the pH probe must be connected to the second channel. To get started, connect the probe to the instrument as indicated in Fig. 10 o 10.1 (depending on the instrument in possession).

1. power cord
2. electrode
3. BNC connector

The pH probe **MUST** be connected to input 1 allocated for measurement 1, pH, see Fig. 7

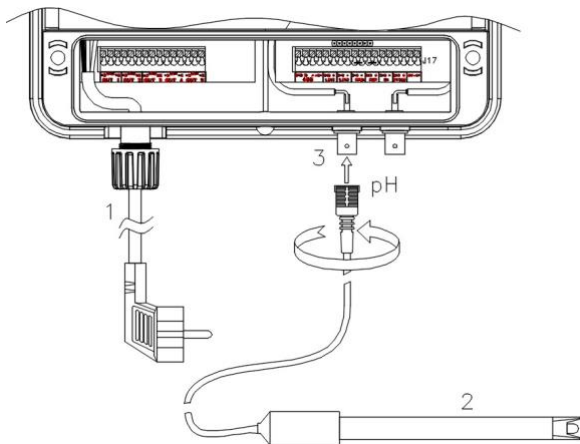

Fig. 10 – pH electrode connection (eTwin pH-Rx o pH-pH)

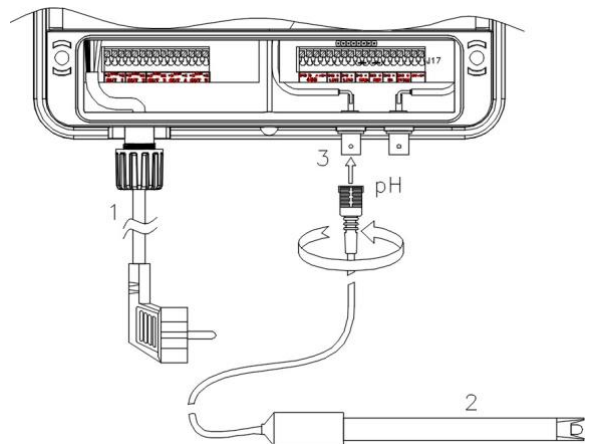

Fig. 11.1 – pH electrode connection (eTwin CI-pH)

Rx probe connection

The following instructions apply to all eTwin pH – Rx models. To get started, connect the probe to the instrument as indicated in Fig. 11

1. Power cord
2. Electrode
3. BNC connector

The Rx probe **MUST** be connected to input 2 allocated for measurement 2, Rx,

Fig. 12– Rx electrode connection

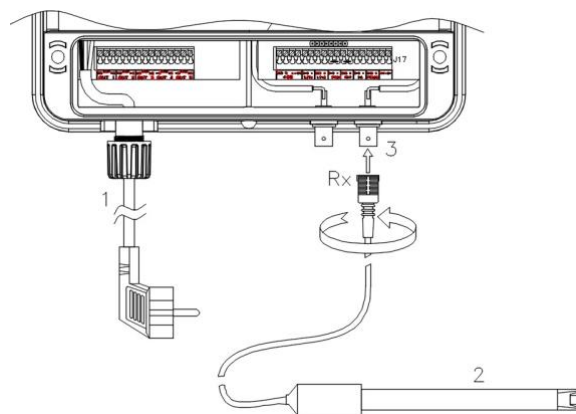

Cl probe connection

The instructions in this paragraph apply to eTwin Chlorine - pH models. The Chlorine probe must be connected to the pump through the specific cable: having connected BNC, the remaining two cables must be inserted in the cable gland and connected to the “inputs” terminal board.

1. Power cord
2. Chlorine probe
3. BNC connector
4. Chlorine probe power cord

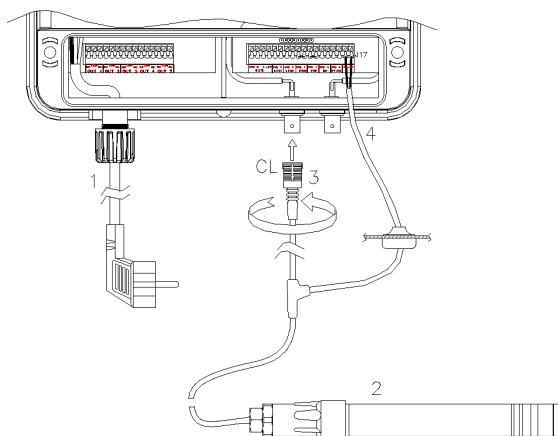

Part number	Connection
ASO0001701	Connect the power cords of the probe to terminals 17 (+5V (brown wire) and 18 (-5V white wire) of terminal board J8 (right terminal board)
ASO0001702	
ASO0001603	
ASO0001604	
ASO1000101	Connect the power cord of the probe to terminal 17 (+5V – positive RED)
ASO1000102	
ASO1000201	
ASO1000202	

PROBES CALIBRATION MENU

To allow the device to correctly detect the parameters of the water to be checked, the probes connected to it must be calibrated. Either electrodes made of glass or plastic can be used. The instructions for calibrating the probe apply to all eTwin device models and versions



During the calibration, the pH, Rx and PPM values displayed on the left of the screen represent the real time values of the reading of the probe, while those displayed on the right of the screen are the values of the BUFFER solutions used to calibrate the different points.



Attention: if calibration is not carried out correctly or the readings are not even made on the instrument, they could have serious errors with non-negligible consequences on the health and safety of the users.



To access the CALIBRATION menu, press  for about 5 seconds.

pH probe calibration

The following steps show how to calibrate the pH probe. To perform the operations, you must have two vials of pH 7 and pH 9 buffer solutions of reference (the solutions are not included in the supply and can be requested separately).

The parameter of the buffer solution (shown on the right of the display) can be changed using the ARROW keys, if you do not have the buffer solutions corresponding to the default settings (pH7 and pH9).

pH procedure:

- Dip the electrode in the pH 7 buffer solution
- Wait for the value at the left of the screen to stabilise
- Confirm by pressing OK
- Wait 90 seconds (according to displayed countdown)
- Dip the electrode in the pH 9 buffer solution
- Wait for the value at the left of the screen to stabilise
- Confirm by pressing OK
- Wait 90 seconds (according to displayed countdown)

At the end of the calibration, the instrument detects the **PROBE QUALITY** parameter, with the percentages indicating the wear conditions of the probe.

The possible results are: 100%, 75%, 50%, 25%, *CALIBRATION ERROR*. The last parameter means that the calibration was not successful due to an error in the procedure, or that the probe is to be considered no longer usable.

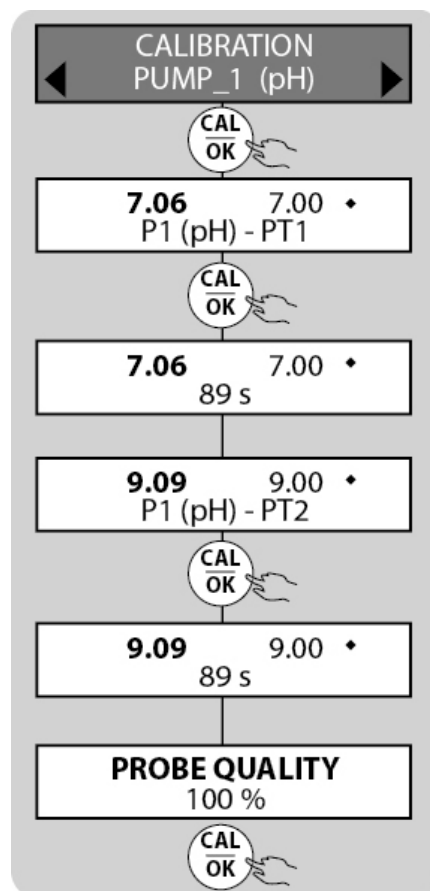

Rx probe calibration

The following steps show how to calibrate the Rx probe. To perform the operations, you must have a vial of 650 mV buffer solution of reference (the solution is not included in the supply and can be requested separately).

The parameter of the buffer solution (shown on the right of the display) can be changed using the ARROW keys, if you do not have the buffer solution corresponding to the default setting (650 mV).

Rx procedure:

- Dip the electrode in the mV 650 buffer solution
- Wait for the value at the left of the screen to stabilise
- Confirm by pressing OK
- Wait 90 seconds (according to displayed countdown)

At the end of the calibration, the instrument detects the **PROBE QUALITY** parameter, with the percentages indicating the wear conditions of the probe.

The possible results are: 100%, 75%, 50%, 25%, *CALIBRATION ERROR*. The last parameter means that the calibration was not successful due to an error in the procedure, or that the probe is to be considered no longer usable.

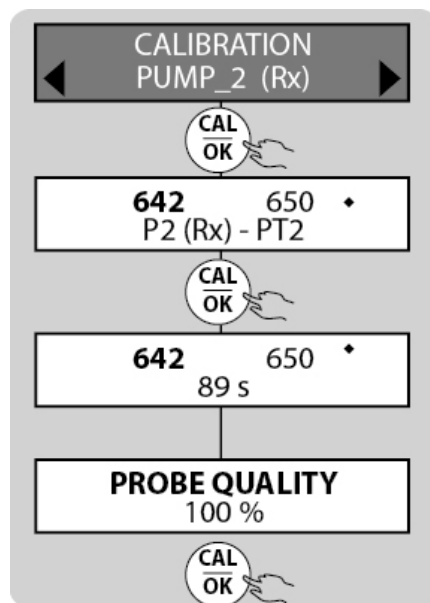

Cl probe calibration



Before performing the calibration, you must modify the PPM VALUES SCALE parameter (see relative menu) based on the chlorine probe used.

See the instructions attached to your probe for the preliminary connection and preparation operations of the sensor and relative maintenance.

To perform the calibration operations, you must have chlorine-free water and then the same water with a known content of chlorine.

Attention: this procedure requires that the device be connected to an operating Chlorine probe installed on the system. The measurement for the calibration must be made using the plant's water.

During the calibration, the Chlorine value (PPM) displayed on the left of the screen is the reading value of the probe, while that displayed on the right of the screen is the value of the solution of reference.

Install an "active carbon filter" upstream of the probe and have water flow in it for at least 10 minutes, in order to eliminate traces of chlorine and to perform the calibration of the first point.

For the second point, add product and use a photometer or a DPD system to read the PPM values. Then modify the value of reference according to that read by the manual measurement. The following is the sequence of operations to calibrate the probe.

Cl procedure:

- Install the chlorine probe in the probe holder, flow water through the plant, connect the probe electrically and wait for it to polarise (approximately 2 hours – see the relative probe manual)
- Install an "active carbon filter" upstream of the plant and have water flow in it for about 30 minutes
- Wait for the value at the left of the screen to stabilise
- Confirm by pressing OK
- Wait 90 seconds (according to displayed countdown)
- For the second point, remove the "active carbon filter" and use a DPD system to read the chlorine in the plant. Insert the read value, shifting by using the UP/DOWN arrows (changing the value on the right of the screen) and confirm by pressing OK.
- Wait 90 seconds (according to displayed countdown)

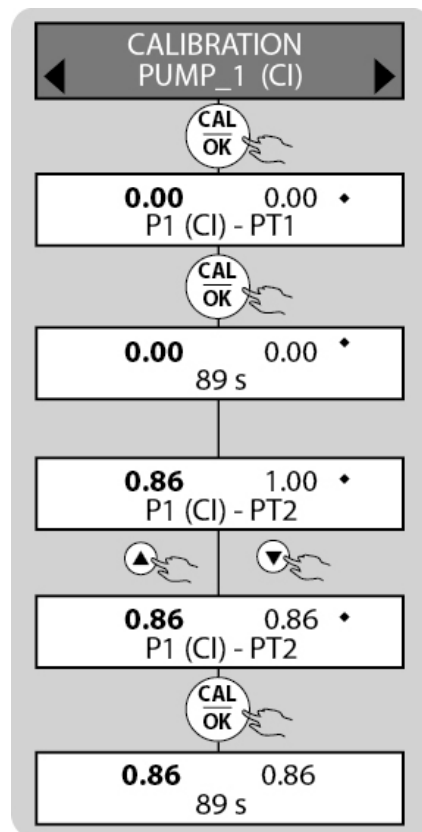

MANUAL MODE SETTING MENU

This configuration is present in all versions. The dosing pump operates at a frequency pre-established by the user and is included in the following ranges:

- 0 ÷ 120 pulses / minute (electromagnetic pump)
- 0 ÷ 100% (peristaltic pump) (motor cycle time 300s.)

During the operational phase of the manual function, it is possible to display the pulses / minute (electromagnetic pump), the percentage of dosage (peristaltic).



To enter the manual function, place the instrument in **PAUSE** mode, by pressing the keys simultaneously. Press **UP** arrow to put the **LEFT** pump in hand, or the **DOWN** arrow for the **RIGHT** pump.

Only one pump or both can be placed in MANUAL at a time.



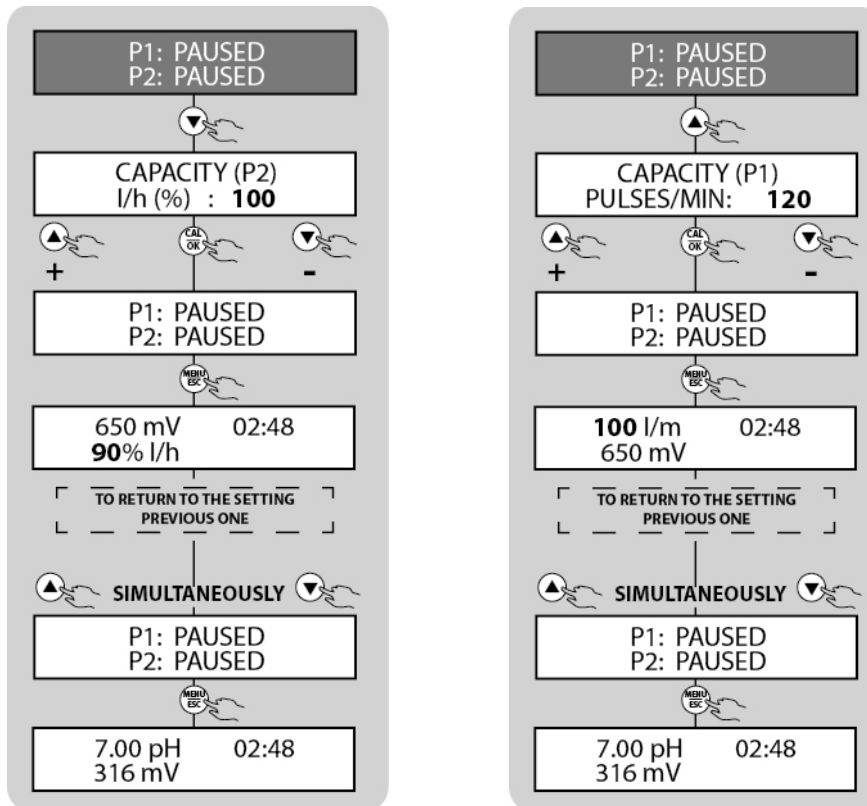

Use the arrows to make the adjustment. Press the **OK** button and then the **ESC** button. The selected pump will go to the frequency / percentage established by the user.

To exit the **MANUAL** function, and return to the instrument function (pumps controlled by the measurement of the probes), simultaneously press the **ARROWS** (IN PAUSE) and then the **ESC** key.



SETTINGS MENU

To access the SETTINGS MENU, press  for at least 5 seconds both from MEASUREMENT mode and from PAUSE.

The following image shows the list of the different items of the SETTINGS submenu which can be accessed. Since it is a circular menu, the device stores the last item selected before exiting by pressing . You may scroll the different items using the  and  keys and then selecting the concerned item by pressing .

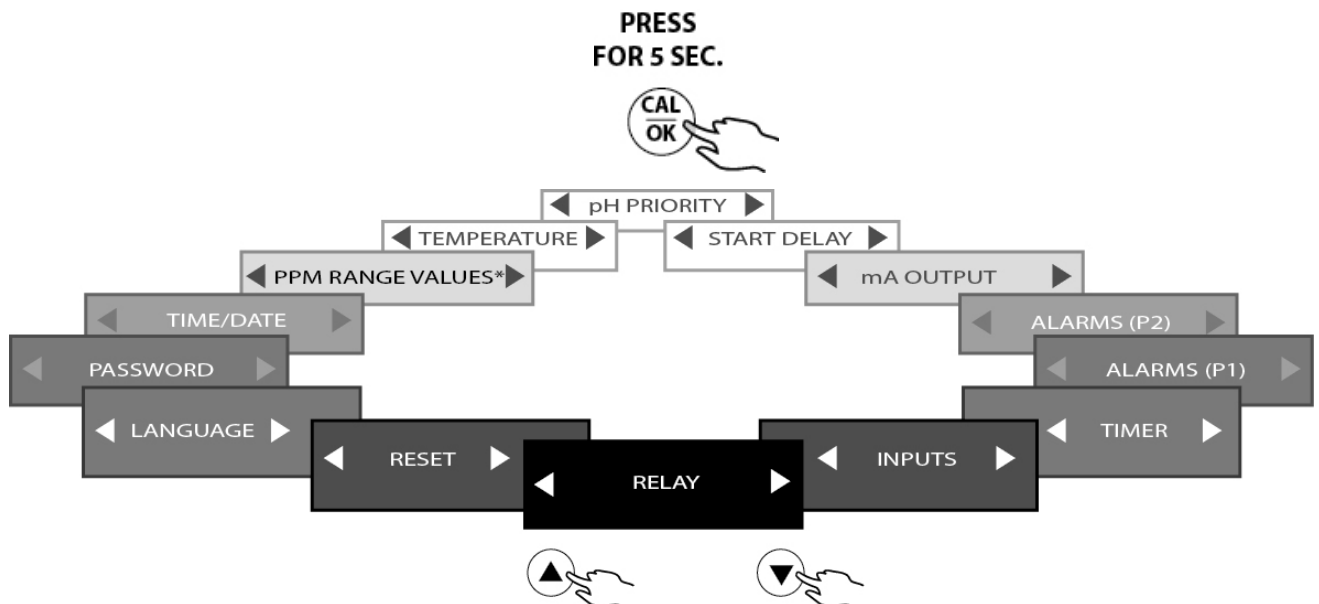

*PPM SCALE VALUES menu only included in the eTwin CI-pH version

The following paragraphs extensively explain the operating procedures for configuration of the auxiliary functions.

Relay outputs

You may set three relay outputs independently, associated respectively to:

- PUMP_1 (pH), or Chlorine
- PUMP_2 (Rx), or else pH, depending on the model
- TIMER
- TEMPERATURE



Refer to fig. 9 for the connection of the relays. By default, RELAY 1 is associated to Pump_1, RELAY 2 to Pump_2 and RELAY 3 to the TIMER. **The timer of the relay function is independent from the timer function described in the following paragraph. There are however four daily cycles, or else 4 cycles for each day of the week.**

It is possible to decide whether to enable the relay even in the absence of flow (default DISABLED)

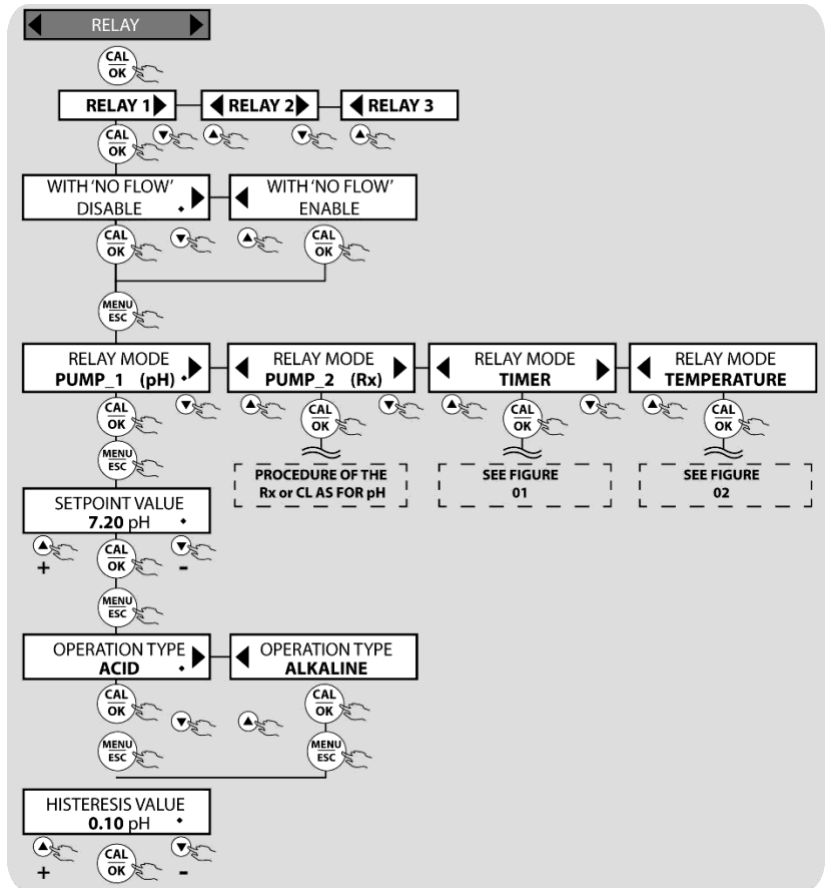

FIGURE 01

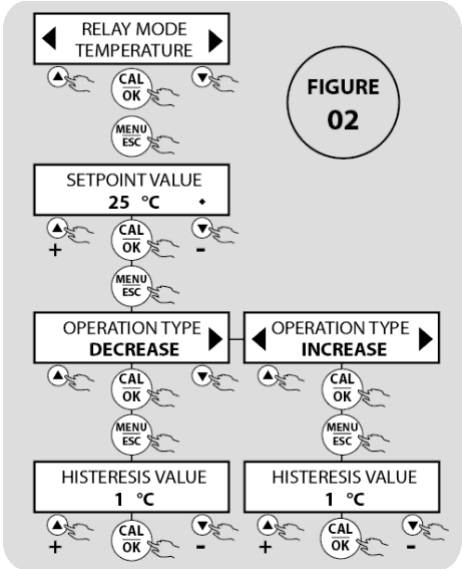
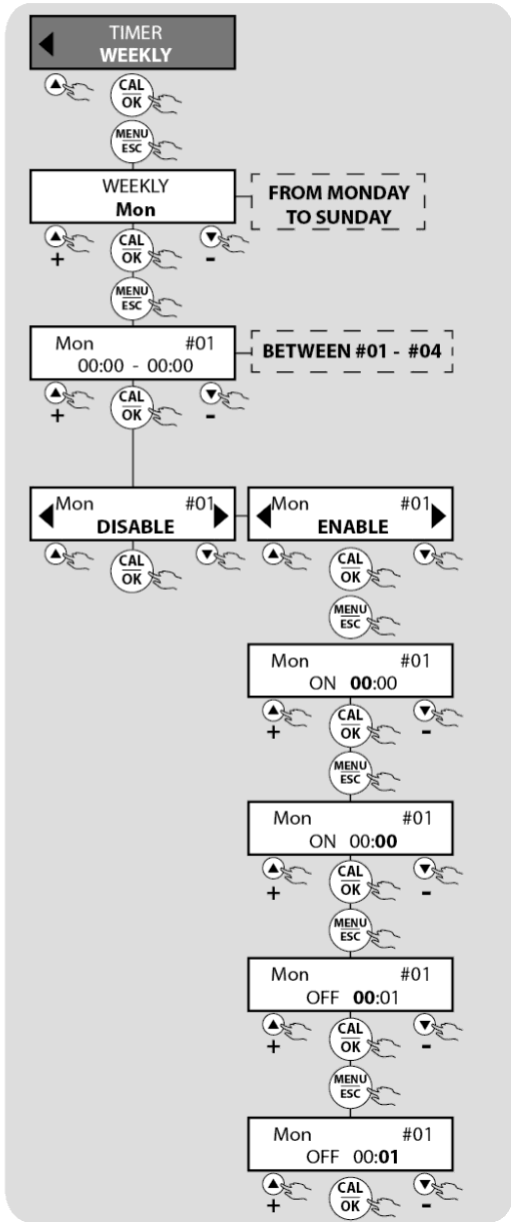
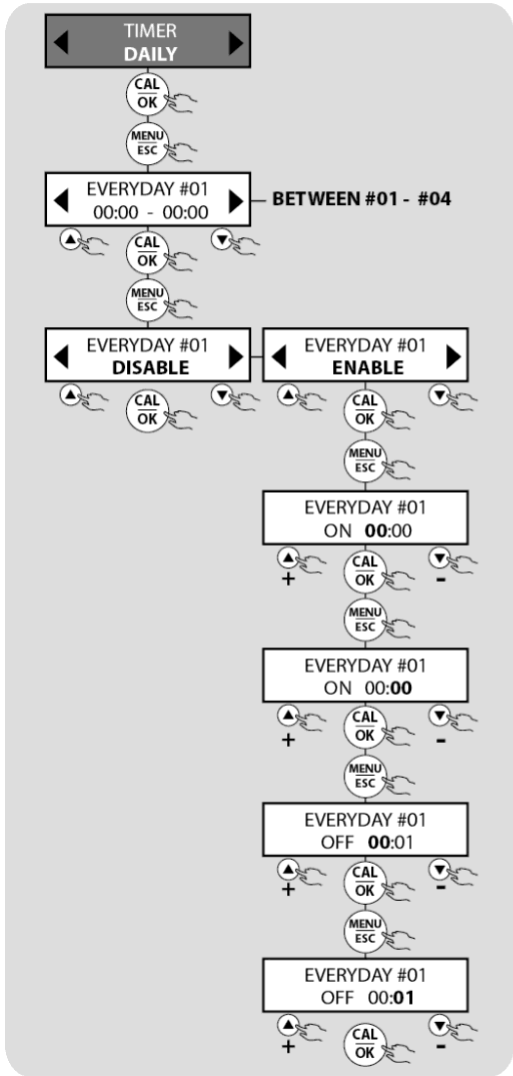

FIGURE 02

Similar procedures can be followed to configure the outputs connected to RELAY 2 and RELAY 3

Inputs

You may set the operating parameters of 4 different external inputs:

- LEVEL 1 (5-6)
- LEVEL 2 (7-8)
- FLOW SENSOR (proximity) – (9-10)
- EXTERNAL COMMAND (11-12)

Refer to Fig. 8 for the connection to the respective terminals

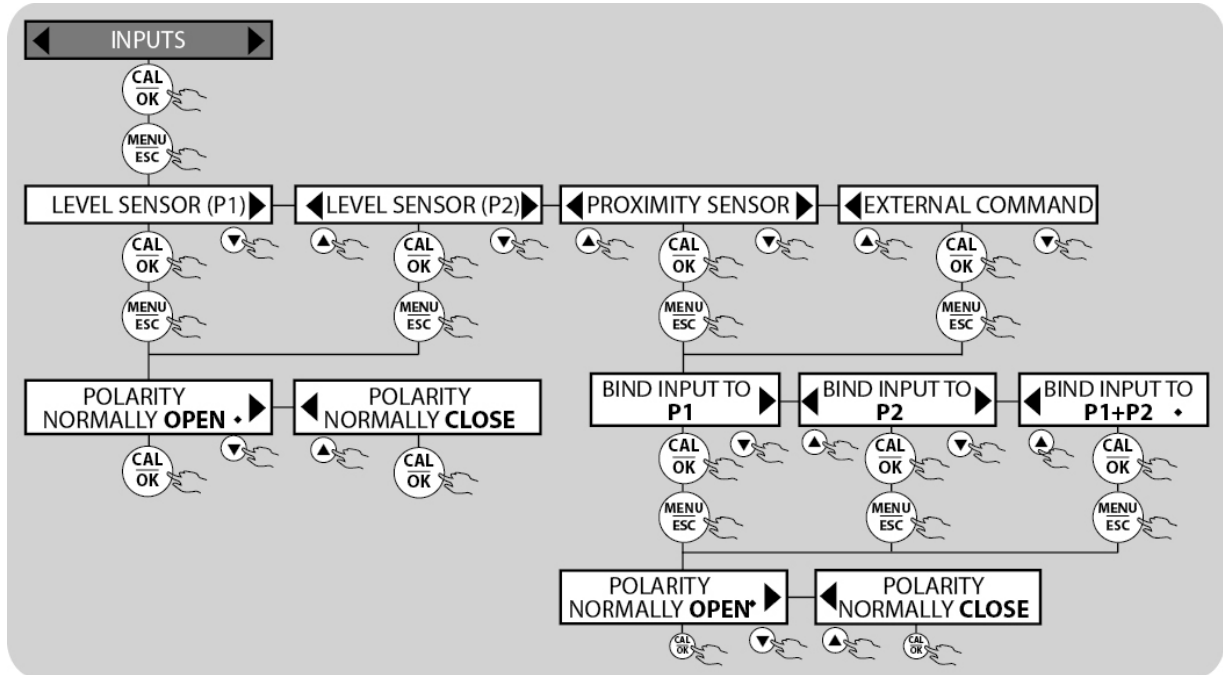

By DEFAULT, the proximity sensor and the external contact are set at NORMALLY OPEN. Therefore if the contacts open, the device displays this on the screen and the pumps are blocked.



Attention: it is strongly recommended to use the device coupled to a flow sensor (proximity) which gives consent for dosage only when the flow passes through the plant.

The device is supplied with the terminals of the PROXIMITY SENSOR and EXTERNAL SIGNAL jumpered, (see Fig. 8), so that, with the default settings, the device can operate without connecting external sensors.

Eliminate these jumpers when the consents are used. Otherwise check whether the overdosage alarm triggers with a time compatible with the application. By default, this alarm triggers with a control time of 10 minutes.

Timer

The Timer menu function manages the operating status of the instrument in all its set functions. The timer is designed so that there can be 4 start cycles (Instrument Active) and Stop cycles (Instrument not running) in one day. You can also manage 4 start and stop cycles for each day of the week. The following selections can be made:

- **TIMER DISABLED** The timer is deactivated.
- **DAILY TIMER** By enabling this selection, the user can select 4 start and stop cycles during the day
- **WEEKLY TIMER** By enabling this selection, the user can select 4 start and stop cycles for each individual day of the week: Monday, Tuesday etc.



During the timer triggering period (ON) the display shows the measurements. Vice versa, when the device is off, again under timer, the display shows the date and time. If the timer is enabled by error, it is recommended to disable it or to reset the parameters.

Before setting the timer, correctly set the current date and time. See the relative paragraph

DAILY TIMER setting. It is possible to set up to 4 daily operating cycles. Follow the steps indicated below to set the cycles.

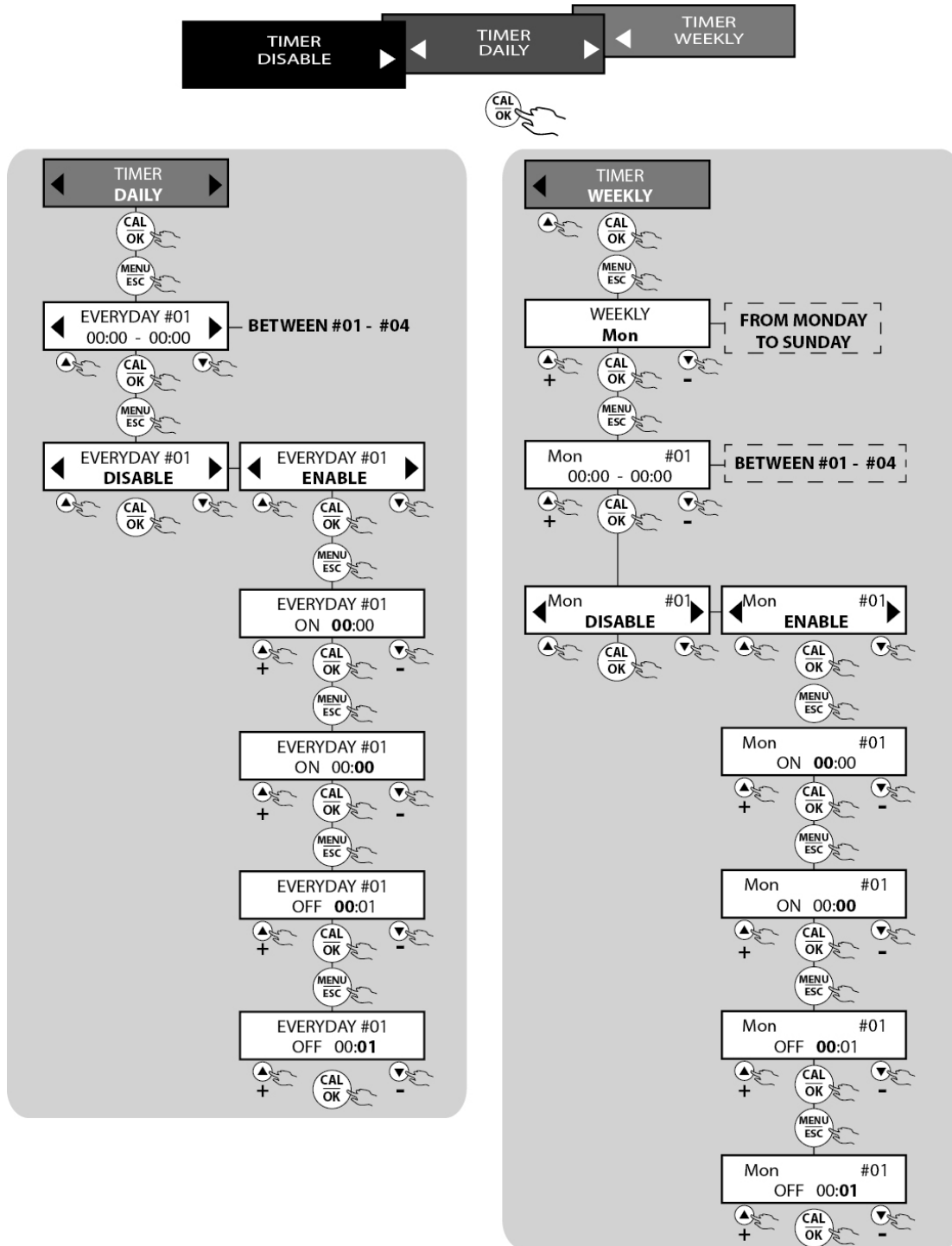

WEEKLY TIMER setting. It is possible to set up to 4 operating cycles for each day of the week. Follow the steps indicated below to set the cycles.



Alarms

The eTwin pump can monitor correct operation of the system and signal some alarm situations which can occur; to be more specific, the following alarms can be triggered:

- Level alarm
- Maximum value alarm
- Minimum value alarm
- Overdosage alarm

All the alarm situations are associated independently to pump 1 and 2. They are signalled by displayed messages and are disabled by active relay outputs. When several alarms are triggered, they may be viewed using the  and  keys. The alarm relay (REL5 contacts 13, 14 and 15) can also be switched, if enabled, by different configuration menus, where foreseen.



Triggering of the Overdosage Alarm always enables switchover of the REL5 alarm relay.

The following procedures show the different steps to follow to set the operating parameters of the alarm warnings of Measurement 1 (pH), P1. The same procedure applies to Measurement 2 (Rx), P2.

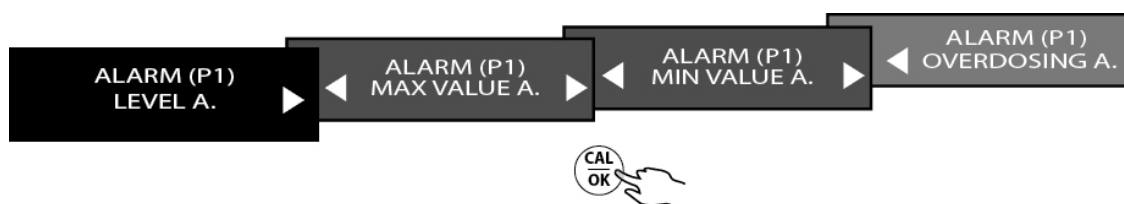

Level alarms

The device allows you to connect a level sensor to each measuring channel. To configure this input, follow the sequence below.

The float level probe signals when the liquid to be dosed in the tank is finished. The instrument blocks, signalling the alarm status. Connect the level probe to the terminal board of the instrument and introduce it in the tank containing the additive which must be dosed. To avoid false alarms due to oscillations of the liquid level, the alarm is triggered with at least a 3 sec. delay. It is possible to associate a relay output to the level alarm. See the next paragraph for its programming.

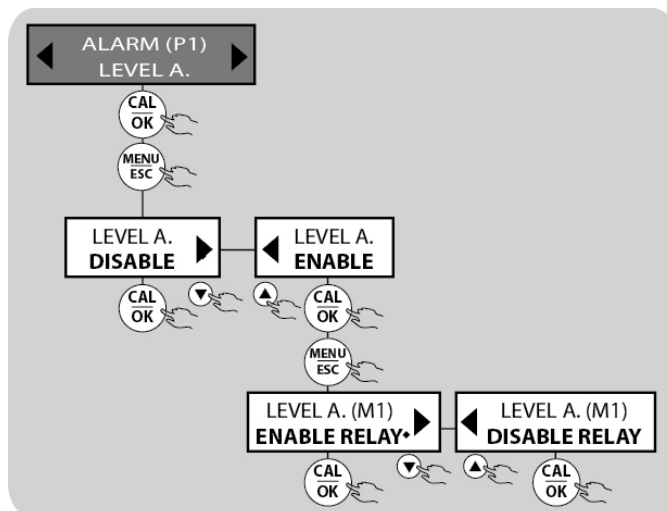

Maximum value and minimum value alarms

The device controls holding of the values of the electrochemical parameters of the water (pH, Redox, Cl) within the parameters set when programming the device. During normal operation of the system, faults could occur and the measured values could be outside of the normal operating condition. Two alarm thresholds can be set: respectively "MAXIMUM VALUE" and "MINIMUM VALUE". When these are exceeded, the operator must intervene to find out what determined their triggering and to restore correct operating conditions.

Usual causes which can generate this alarm situation can be:

- Lack of additive in the suction tank;
- Leaks in the treatment system;
- Incorrect concentration of the dosed additive;
- Sensor breakage



The maximum or minimum alarm condition disables all the relay outputs.

To eliminate the ALARM, press OK and then ESC (only if the values have returned within the non-alarm range). If the values are still within the alarm threshold, to enter the MENU, press OK (the instrument goes in PAUSE) and then press ESC for about 5 sec.

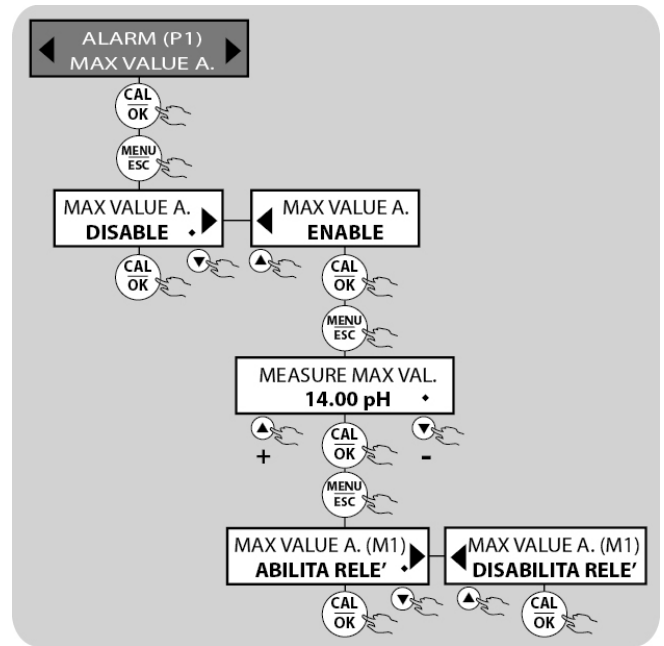
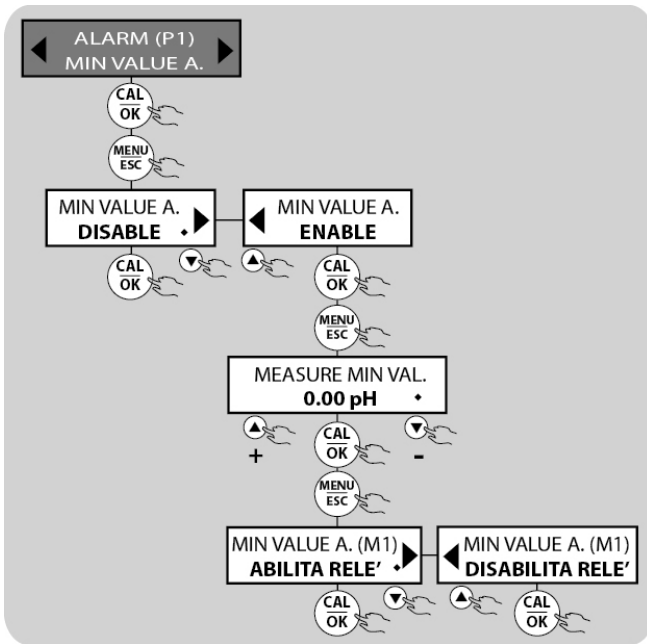

The same procedure must be repeated on measurement 2 (P2) – Redox

Overdosage alarm

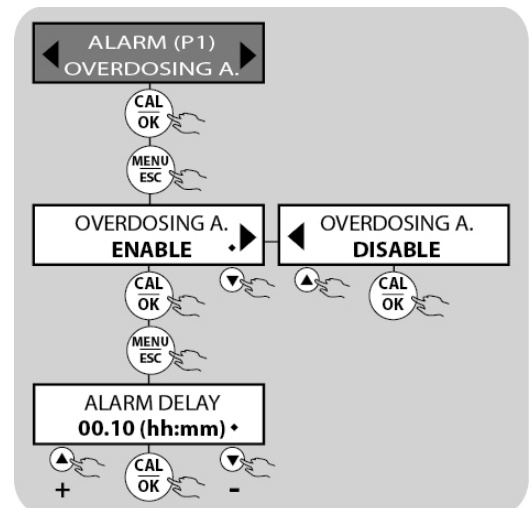

An alarm could be triggered if the set-point values are not reached after a certain amount of time set by the user. By default, this alarm triggers with a time of 10 minutes. **The relay output REL5 is always enabled**

The following are the steps for setting the operating parameters of the function.



mA output

The device is equipped with an analogue output in 4-20 mA current which can be associated to only one measuring channel chosen by the user (See Fig. 8 - terminal board for the connection). The following procedure shows the different steps to carry out to set the parameters.

The same procedure can be repeated if, ON THE OTHER HAND, it is decided to associate the mA OUTPUT to measurement 2, Rx or pH depending on the models. The value of the mA output can be viewed in RUN mode by pressing  and go back to viewing the MEASUREMENT by pressing .

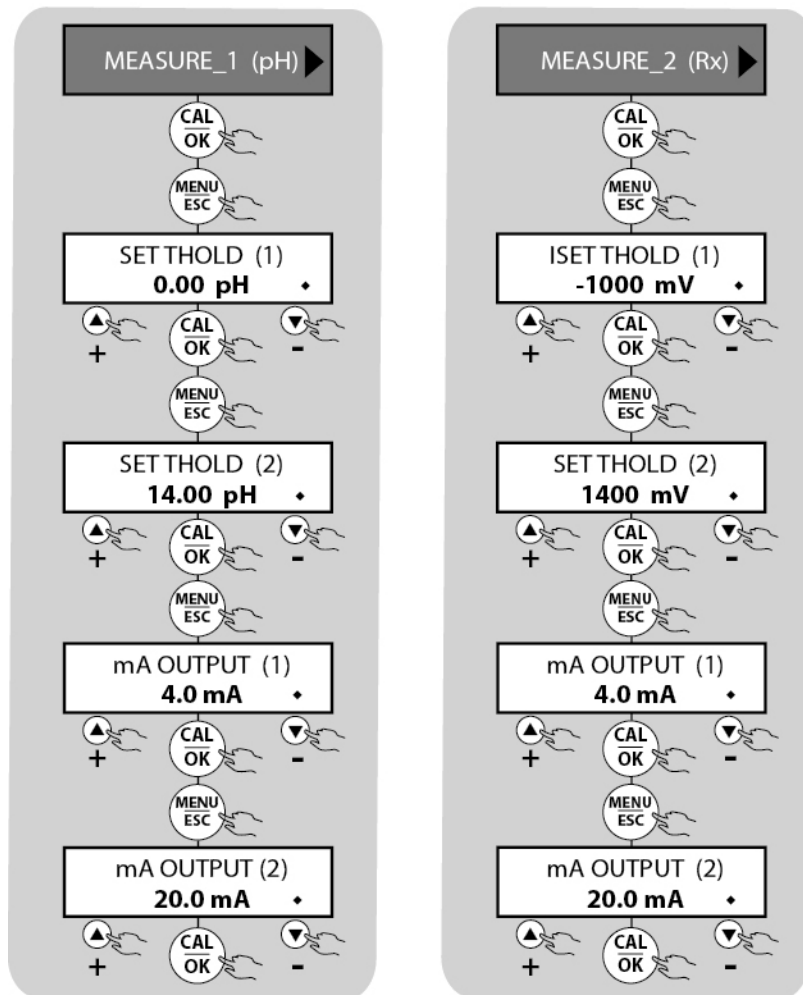
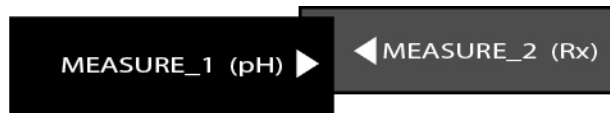
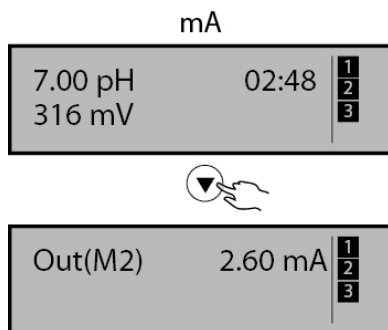

Visualization of the probe mVs

It is possible to view the real signal in mV that the probes send to the instrument. During the reading of the measurements, press the ARROW LOW button twice in succession.

After a few seconds the display automatically returns to the run time display.

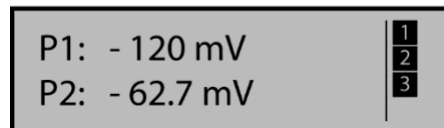
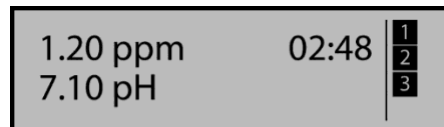

Activation delay

If intervention of the pumps needs to be delayed, a delay can be set in **hh:mm**. The maximum time interval that can be set is **03:00 hh**. The activation delay can be enabled independently on pumps 1 and 2. The countdown is triggered when the instrument is powered and viewed on the display. The following is the sequence of operations to be followed:

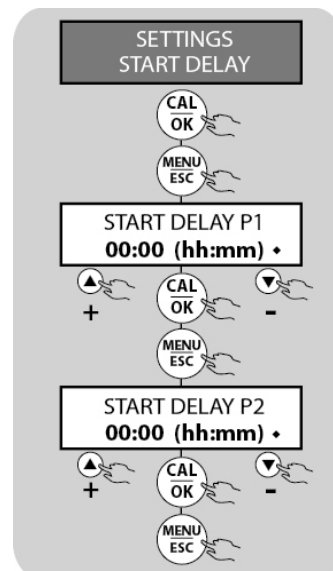

pH priority

The pH priority can be ENABLED. Activating this function enables dosing only for pump pH if the set point is reached simultaneously. By default, the function is set at DISABLED.

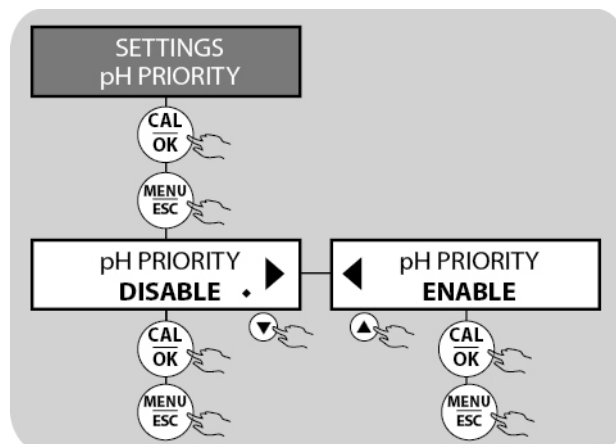

Temperature

One of the following functional modes can be selected:

- **MANUAL** – the value the user sets in the configuration menu represents the parameter of reference for compensation of the pH value (default setting 25°C).
- **AUTOMATIC** – the value measured by the PT100 probe represents the parameter of reference for compensation of the pH value.

The default mode is set at MANUAL at 25°C. To switch to AUTOMATIC mode, follow the operations below (in the same menu you may choose the unit of measurement of the temperature between °C and °F).



When set at **AUTOMATIC**, the display shows the temperature value measured by the external probe.

When MANUAL mode is chosen, the default value of 25°C (77°F) of the temperature of reference can be modified in the measurement configuration menu. See the measurement setting paragraph.

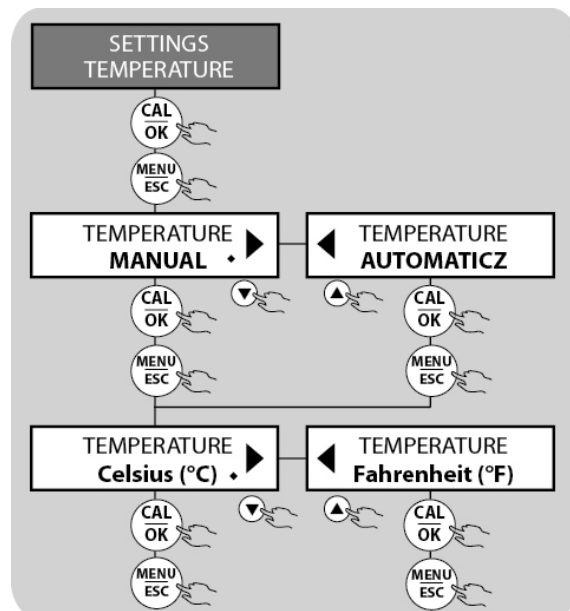

PPM scale values

Depending on the type of chlorine probe used, the full scale intervals of the measurement on channel 2 can be chosen for Chlorine - pH model instruments.

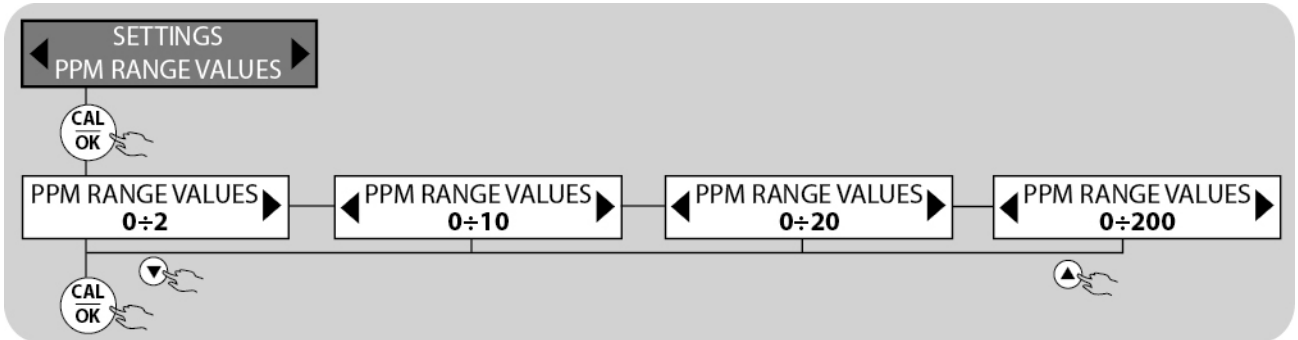

Clock



Some applications could require programming activation or deactivation of the device. This is why the electronic device is equipped with a clock and calendar; the following settings can be made:

CLOCK hh:mm – Day (Hours : Minutes –
MON/TUE/WED/THU/FRI/SAT/SUN)

DATE Day/Month/Year.

The time is displayed on the screen in MEASUREMENT mode. If the timer function is enabled, the complete time and date are displayed while the device is in standby

The following are the various steps to set the CLOCK function.

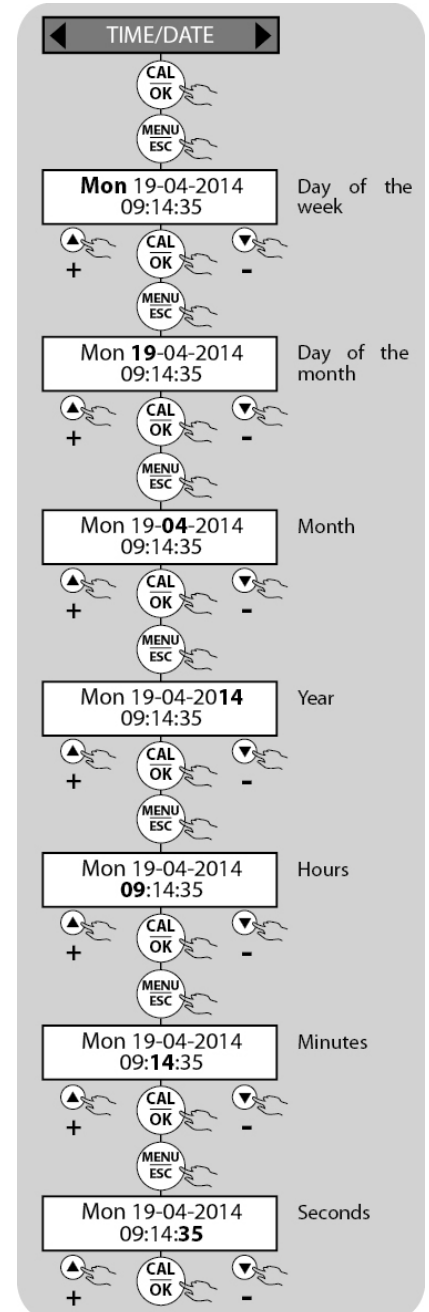

Password



A password can be set to protect, even separately:

- CALIBRATION
- SETPOINT
- SETTINGS
- STAND-BY

The password has 4 numbers and is unique. By default, the passport is disabled on all the sections. The following are the indications for setting the functional parameters

If you've lost the password, contact CUSTOMER SERVICE to restore the device.

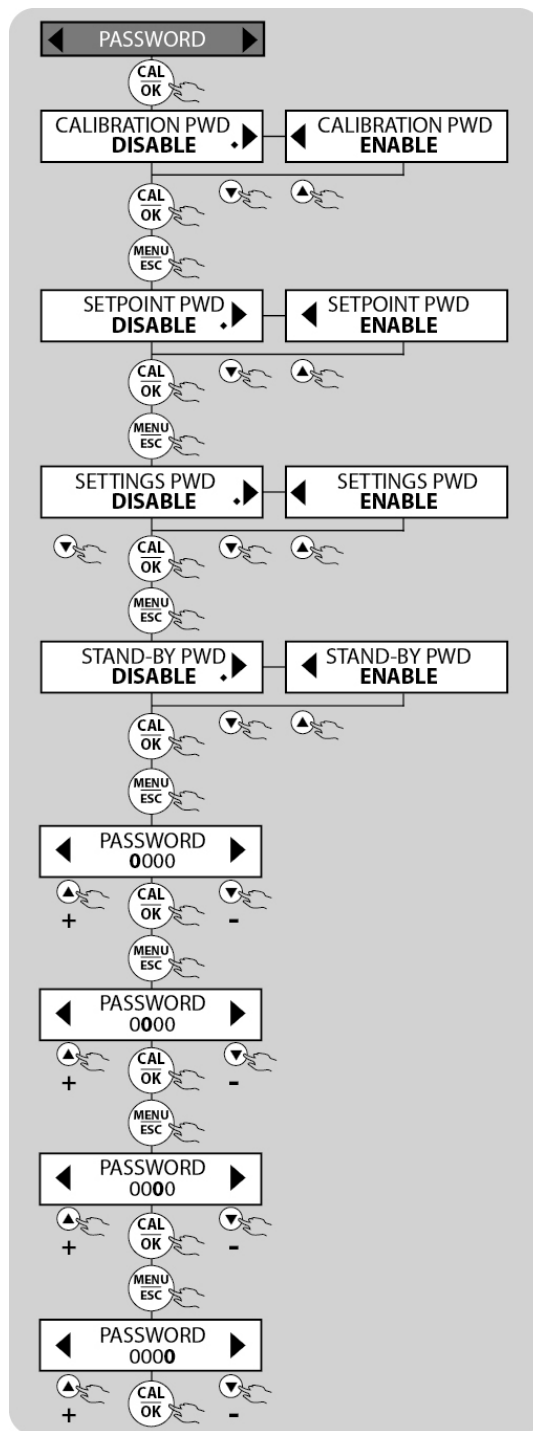

Setting the language

It is possible to choose between 7 languages. ENGLISH (default), ITALIAN, FRENCH, PORTUGUESE, SPANISH, GERMAN, RUSSIAN, to view the displayed messages. Set the LANGUAGE as follows:

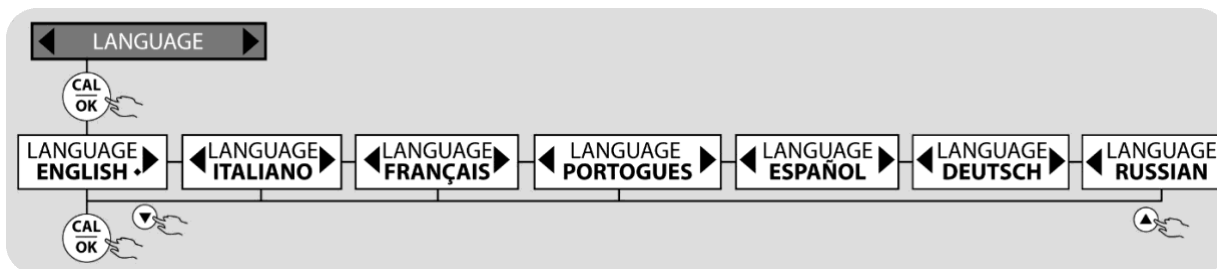

Reset



If needed, two types of reset can be set:

- **PARTIAL RESET:** the user settings are reset, except the language and calibration
- **TOTAL RESET:** the instrument is restored to factory conditions, by default the language is set in ENGLISH.

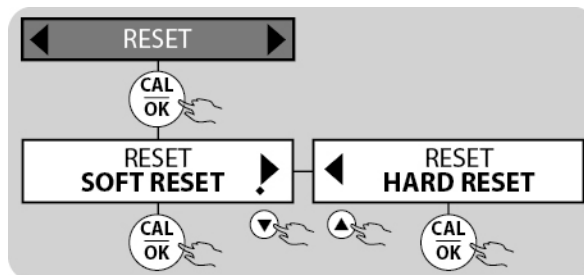

MAINTENANCE

Check the level of the tank containing the oil to be dosed regularly, to prevent the pumps from running dry. Even if the device does not suffer any damage, this control is recommended to prevent damage resulting from lack of additive in the plant. The devices of the eTwin series are designed for the level check. By applying the level probe (not included in the supply), you can monitor the level of the liquid to be dosed contained in the tank. When this level drops below the minimum level established, the pumps stop automatically, a warning appears on the display and the alarm relay 5 switches.

At least every 6 months, check operation of the pumps, tightening of the screws and sealing of the gaskets. Perform these checks more frequently for particularly aggressive liquids. Especially check concentration of the additive in the plant. This concentration could be reduced due to wear of the pinch tube (which must therefore be replaced) or clogging of the filter, which must be cleaned as explained below.

The Manufacturer recommends cleaning the hydraulic part regularly (valves, filter and tubes). The frequency of this cleaning operation cannot be established beforehand as it depends on the type of application, and neither can the reagent to be used be established as it depends on the additive used.

Given these conditions, we can suggest how to intervene if the pump works with sodium hypochlorite (the most frequent situation):

- 1) Make sure it is switched off electrically (both polarities), disconnecting the conductors from the contact points of the mains by means of the omnipolar switch with at least 3 mm between the contacts;
- 2) Disconnect the supply tube from the plant;
- 3) Remove the suction tube (with filter) from the tank and dip it in clean water;
- 4) Power on the pump and have it washed with water for 5÷10 minutes, making sure that no product residues are left in the hydraulic parts;
- 5) With the pump disconnected, dip the filter in a solution of 10% hydrochloric acid and wait for the acid to finish its cleaning action;

- 6) Power on the pump again having it washed with 10% hydrochloric acid for 5 minutes, implementing a closed circuit with suction and supply tubes dipped in the same container;
- 7) Repeat this operation with water;
- 8) Reconnect the pump to the plant.

INTERVENTION ON ETWIN PUMPS IN CASE OF FAILURE

Mechanical failures

Since the system is robust, actual mechanical failures do not occur. Liquid can at times leak from a loose fitting or tube clamping ring nut, or simply if the pinch tube bursts. In that case these components must be replaced. When the leak has been repaired, flush any additive residues out which by stagnating could chemically attack the chassis and damage the inner circuit. If the dosing liquid is missing, depending on the version:

FOR THE PERISTALTIC VERSION

- 1) Check that the pumping tube and suction and supply tube are intact. If any swelling or wear is detected in the tubes, check the chemical compatibility of the additive with that type of tube.

FOR THE ELECTROMAGNETIC VERSION

- 1) Diaphragm worn, replace it;
- 2) Burnt fuse on magnet, replace it (check the resistance of the magnet)
- 3) Electromagnet burnt, replace it

FOR ALL VERSIONS

- 1) Check the status of filter clogging.
- 2) Check the status of the injection valve

Electrical faults

THE INSTRUMENT DOES NOT MEASURE CORRECTLY.

- 3) Check calibration of the instrument
- 4) Check that the electrode or probe works properly

THE PUMP DOES NOT DOSE (INSTRUMENT POWERED AND DISPLAY ON)

Check the "Setpoint".

Check that the timer function is set correctly

Check the ACID/ALKALINE, OXIDANT/REDUCING AGENT or DIRECT/INVERSE setting

WITH ADDITIVE MISSING, THE INSTRUMENT DOES NOT TRIGGER THE ALARM (for instruments supplied with level probe)

Check the connection between the level probe and the terminal board, short circuiting the terminals (see WIRING chapter). If the pump triggers an alarm, the probe must be replaced. Otherwise contact our Service Centres.

Attention: When removing the device from the system, carefully slip the tube off the supply fitting of the pumps, as any residual additive inside the tube could escape. Thoroughly clean any chemical residue on the chassis of the device

DRAWINGS

Peristaltic and Electromagnetic Pump Exploded Drawings

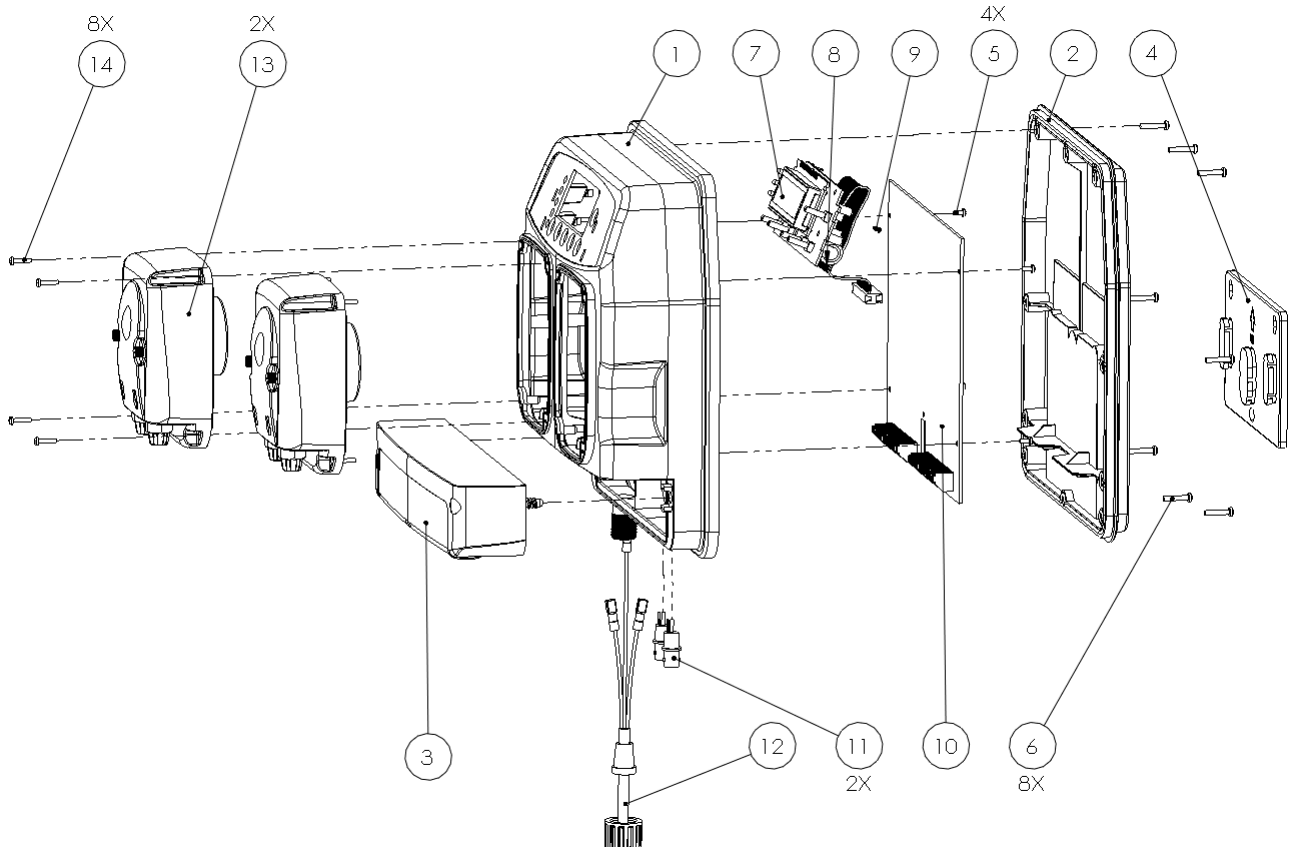

PERISTALTIC

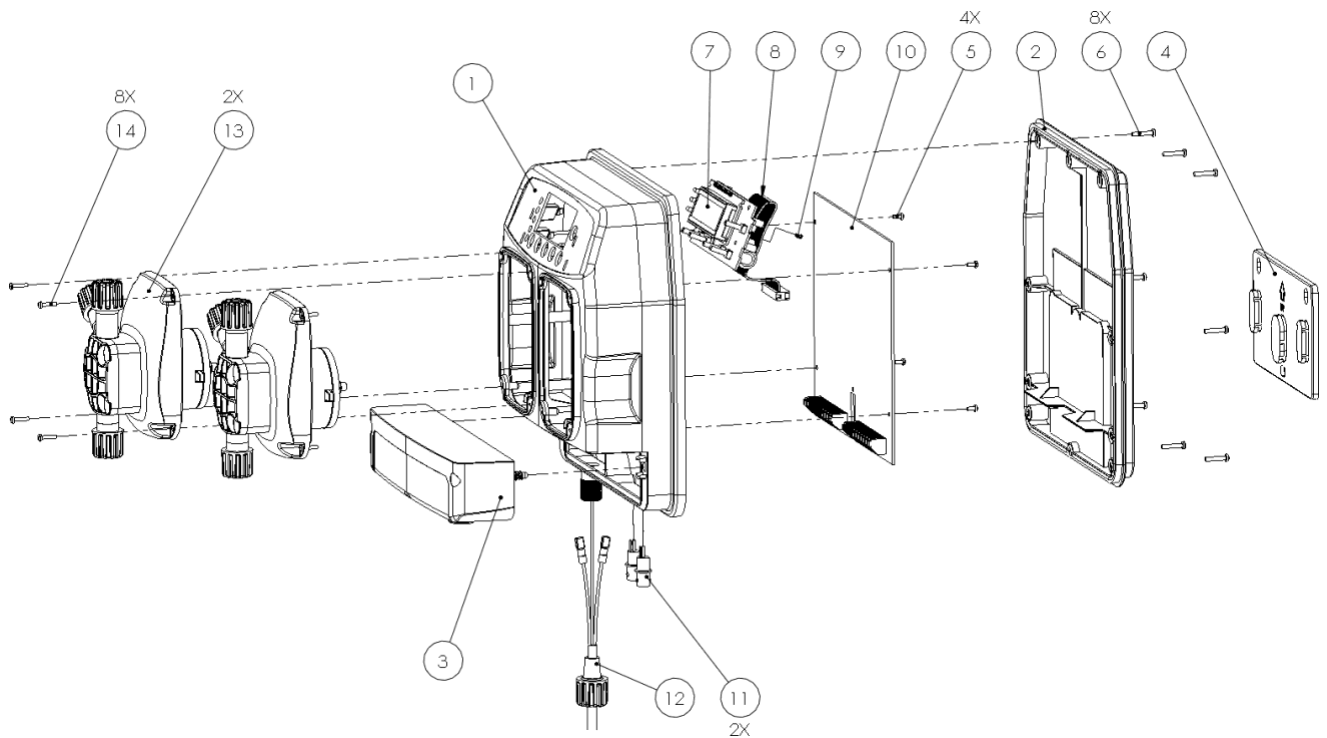

ELECTROMAGNETIC

#	DESCRIZIONE DESCRIPTION	CODICE PART. NUMBER	
		PERISTALTICA PERISTALTIC	ELETTROMAGNETICA ELECTROMAGNETIC
1	CASSA CHASSIS	DCA 00033 01	DCA 00033 01
2	COPERCHIO POSTERIORE BACK COVER	DCE 00033 01	DCE 00033 01
3	COPERCHIO MORSETTIERA TERMINAL BOARD COVER	SCE 00035 02	SCE 00035 02
4	STAFFA BRACKET	DSA 00017 01	DSA 00017 01
5	VITE 2.9 x 13 FISSAGGIO SCHEDA ALIMENTAZIONE 2.9 x 13 POWER SUPPLY BOARD FIXING SCREW	4034003	4034003
6	VITE DI CHIUSURA COPERCHIO POSTERIORE BACK COVER LOCK SCREW	DVI 00057 01	DVI 00057 01
7	SCHEDA COMANDI ELECTRONIC COMMANDS BOARD	RPB 00220 21	RPB 00220 22
8	CONNETTORE SCHEDE BOARD'S CONNECTOR	DCN 00061 01	DCN 00061 01
9	VITE 3X8 FISSAGGIO SCHEDA 3X8 FIXING BOARD SCREW	DVI 00075 01	DVI 00075 01
10	SCHEDA ALIMENTAZIONE ELECTRONIC POWER SUPPLY BOARD	RPB 00239 01	RPB 00239 02
11	CONNETTORE BNC CABLATO BNC CABLED CONNECTOR	2103001	2103001
12	CAVO ALIMENTAZIONE POWER CORD	SCV 00035 01	SCV 00035 01
13	GRUPPO POMPA PUMP UNIT	SCA 00034 01 (1.5 - 1.5) SCA 00034 11 (3.0 - 1.5)	SCA 00034 02 (2-6) SCA 00034 12 (5-5)
14	VITE FISSAGGIO GRUPPO POMPA PUMP UNIT FIXING SCREW	4034003	4034003



Rio Refugio 9648 - Parque de Negocios ENEA, Pudahuel, Santiago ~ CHILE
Tel. +56 2 28988221 • www.yalitech.cl